

CoroCut® 90°, 45° and T-shape

Angled inserts for aerospace access

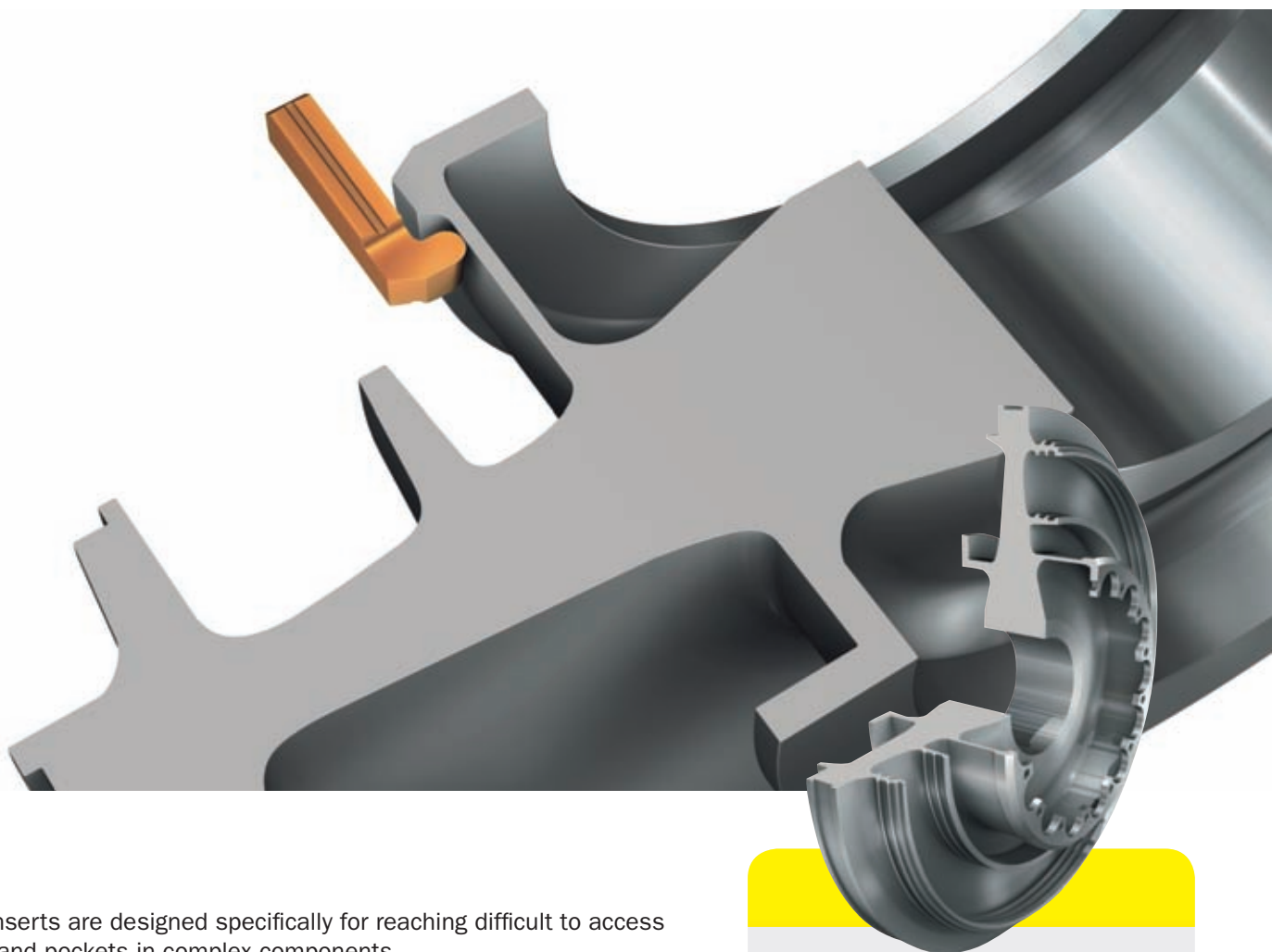

Angled inserts are designed specifically for reaching difficult to access grooves and pockets in complex components.

They offer optimum accessibility, the latest aerospace grade GC1115 and are the perfect solution for machining gas turbine casings, discs and shafts.

CoroCut 90° inserts, 45° and T-shape blanks

These unique tools are top performers in HRSA and titanium. They cut to the highest dimensional tolerances, leaving the component in the optimum condition essential for jet engine and gas turbine production.

A complete offer for difficult to access grooves

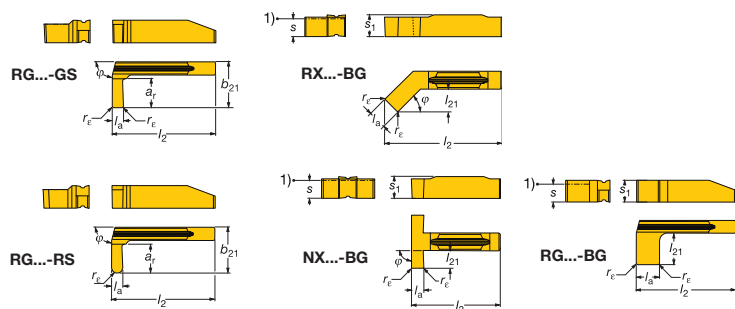
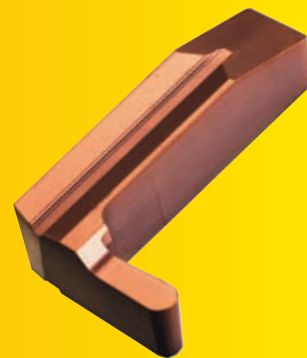

Ordering code	Seat size	Dimensions, mm						Grades					
		l_a	r_ϵ	a_r	b_{21}	l_2	ϕ	GC1115	H13A	H10F	H10		
Inserts													
RG/LG123H1-0200-0002-GS	H	2.0	0.2	4	8	25.55	90°	☆					
RG/LG123H1-0200-0010-RS		2.0	1.0	4	8	25.55	90°	☆					
RG/LG123H1-0300-0002-GS		3.0	0.2	4	9	25.55	90°	☆					
RG/LG123H1-0300-0015-RS		3.0	1.5	4	9	25.55	90°	☆					
RG/LG123H1-0400-0004-GS		4.0	0.4	6	10	25.55	90°	☆					
RG/LG123H1-0400-0020-RS		4.0	2.0	6	10	25.55	90°	☆					
RG/LG123L1-0200-0002-GS	L	2.0	0.2	6	14	30.9	90°	☆					
RG/LG123L1-0200-0010-RS		2.0	1.0	6	14	30.9	90°	☆					
RG/LG123L1-0300-0002-GS		3.0	0.2	9	17	30.9	90°	☆					
RG/LG123L1-0300-0015-RS		3.0	1.5	9	17	30.9	90°	☆					
RG/LG123L1-0400-0004-GS		4.0	0.4	9	17	30.9	90°	☆					
RG/LG123L1-0400-0020-RS		4.0	2.0	9	17	30.9	90°	☆					
Blanks													
		l_a	r_ϵ	l_2	l_{21}	$s^1)$	s_1	ϕ					
		± 0.1											
RX/LX123L1-0600-4500-BG	L	6.00	0.2	40.2	7.6	6.05	6.45	45°	☆	☆	☆		
NX123L2-0400-BG	L	4.00	0.2	31.2	5.0	6.05	6.45	90°	☆	☆	☆		
R/LG123H1-0600-BG	H	6.00	0.2	25.6	8	4.35	5.50	90°	☆	☆	☆		
R/LG123L1-0600-BG	L	6.00	0.2	31	12	6.05	7.40	90°	☆	☆	☆		

1) Cutting edge height after grinding.

90° CoroCut inserts – standard assortment

Grade GC1115

Sharp geometries (RS, GS)

Use standard tool holders

Rigid stability of CoroCut rail tip set

CoroCut 45° and 0° blanks for engineered specials

For grinding to required dimensions

Grades H13A, H10F and H10

For more information please check our catalogue supplement, main catalogue or visit www.coromant.sandvik.com.

Your local Sandvik Coromant distributor:

Head office:
 AB Sandvik Coromant
 SE-811 81 Sandviken, Sweden
www.coromant.sandvik.com
 E-mail: info.coromant@sandvik.com

C-1000:542 ENG/01
 Printed on recyclable paper. Printed in Sweden, AB Sandvikens Tryckeri. © AB Sandvik Coromant 2009.01



Your success in focus